

QUICK CASH AIR CONDITIONING OR  
 ASHP/WITH QUICK CASH STORED WATER  
 NON-METERED  
 FOR LANDIS & GYR  
 Model # FASY-0530-0008

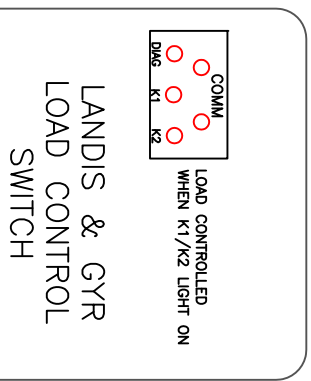

These are wire nut connections

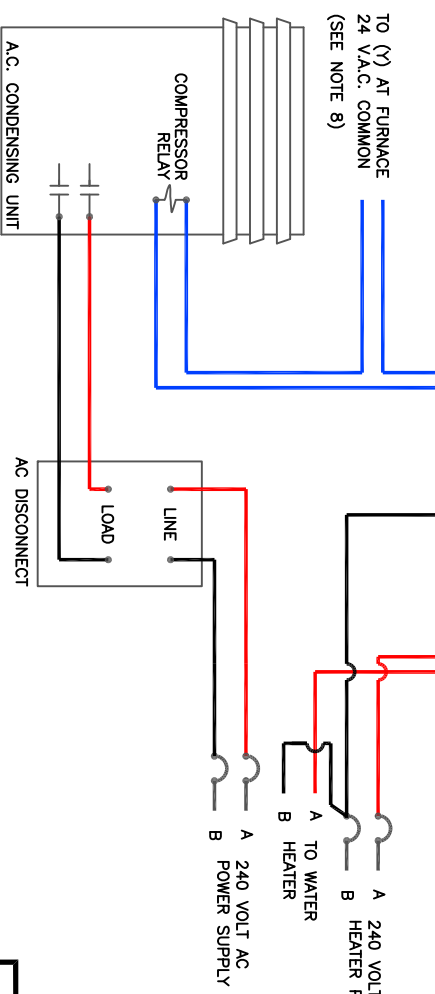

1. Wright Hennepin Cooperative Electric Association will not be responsible or liable for any personal injury or property damage in the wiring of or the operation of this or any Energy Savings Program system. Wright-Hennepin recommends the use of a licensed electrical contractor.
2. All wiring must meet N.E.C. (National Electrical Code) and be inspected by a state electrical inspector before Wright Hennepin will check out installation, credit KWH usage or issue any applicable rebates.
3. The Load Control Receiver control circuitry is to be wired in series with the (Y) circuit to the A.C. unit outside.
4. Load Control Switch must be mounted outside of home and 4' to 6' above the ground.
5. The (A) phase of water heater power is wired in series with the orange wires of the radio receiver.
6. A red light indicates that a load is being controlled.
7. Water heater circuit powers radio receiver.
8. For control of systems with communicating thermostats, see manufacturer instructions to control outdoor unit and program thermostat for utility curtailment.

K1 WATER STORAGE WHEN THE LIGHT IS ON THE WATER HEATERS ARE TURNED OFF  
 K2 ELECTRIC HEAT AND AIR CONDITIONING WHEN THE LIGHT IS ON THE LOAD IS OFF  
 DIAGNOSTIC LIGHT WILL BLINK

K1 - Orange Wire  
 K2 - Blue Wire  
 Red  
 Black } 240 V.A.C. POWER

RETIREMENT  
 ONLY

 <p><b>Wright-Hennepin</b>                  Cooperative Electric Association                  A Touchstone Energy® Cooperative</p>		<p><b>WRIGHT-HENNEPIN COOPERATIVE</b>  <b>ELECTRIC ASSOCIATION</b></p>	
<p>DATE: 4/19/2024</p>		<p>DWG BR: TLG</p>	
<p>PROJECT NO.</p>		<p>CHKD BY:</p>	
<p>SCALE: N/A</p>		<p>APPD BY: LM3C</p>	
<p>ENERGY AND SERVICES DEPARTMENT                  1-800-943-2667                  QUICK CASH AC/ASHP/STORED WATER</p>		<p>SHEET 1 OF 1</p>	