

QUICK CASH STORED WATER
NON-METERED FOR EATON COOPER
Model #6700 RFN

1. Wright Hennepin Cooperative Electric Association will not be responsible or liable for any personal injury or property damage in the wiring of or the operation of this or any Energy Savings Program. Wright Hennepin recommends the use of a licensed electrical contractor.
2. All wiring must meet N.E.C. (National Electrical Code) and be inspected by a state electrical inspector before Wright Hennepin will check out installation, credit KWH usage or issue any applicable rebates.
3. Load Control Switch must be mounted outside of home and 4' to 6' above the ground.
4. The (A) phase of water heater power is wired in series with the blue wires of the radio receiver.
5. A red light indicates that a load is being controlled.
6. Water heater circuit powers load control switch.

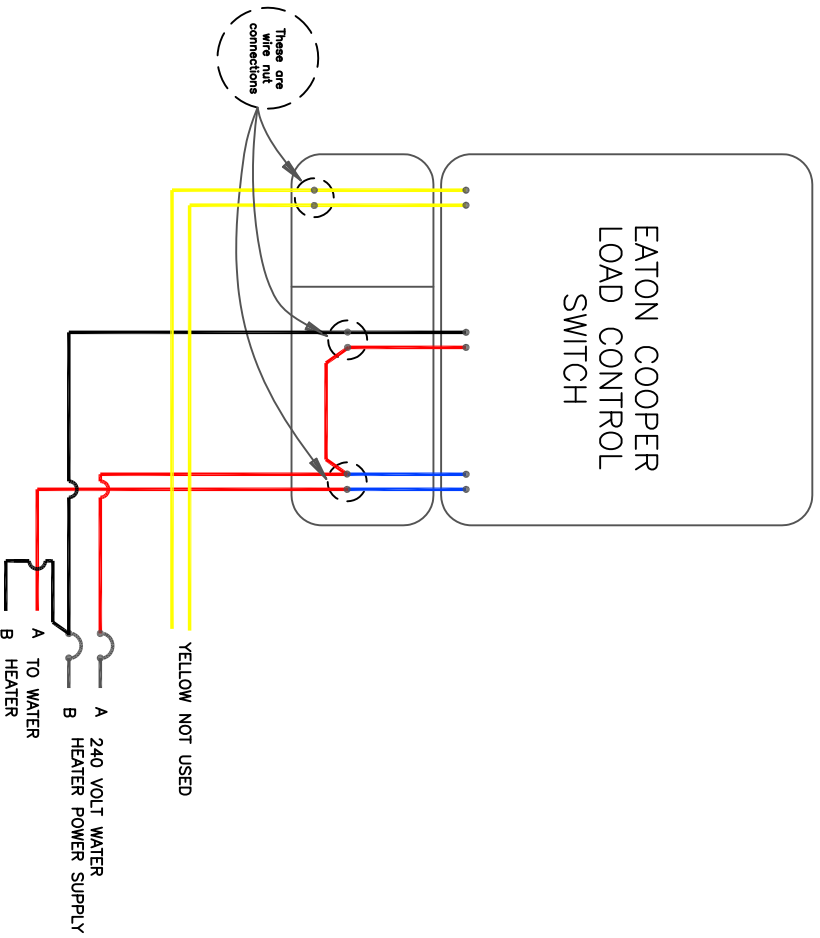

GREEN LIGHT INDICATES POWER TO SWITCH.

WATER STORAGE WHEN THE RED LIGHT IS ON THE WATER HEATERS ARE TURNED OFF

Red } 240 V.A.C. POWER
Black }

 <p>Wright-Hennepin Cooperative Electric Association A Touchstone Energy® Cooperative</p>		<p>WRIGHT-HENNEPIN COOPERATIVE ELECTRIC ASSOCIATION</p>	
<p>ENERGY AND SERVICES DEPARTMENT 1-800-943-2667</p>		<p>QUICK CASH STORED WATER/NON-METERED</p>	
DATE	4/19/2024	DWG BY:	LM3B
PROJECT NO.		SCALE	N/A
		CHKD BY:	
		APPD BY:	
		SHEET	1 OF 1