

QUICK CASH AIR CONDITIONING/ AIR SOURCE HEAT PUMP FOR LANDIS & GYR

1. Wright Hennepin Cooperative Electric Association will not be responsible or liable for any personal injury or property damage in the wiring of or the operation of this or any Energy Savings Program. Wright Hennepin recommends the use of a licensed electrical contractor.
2. All wiring must meet N.E.C. (National Electrical Code) and be inspected by a state electrical inspector before Wright Hennepin will check out installation, credit KWH usage or issue any applicable rebates.
3. The energy savings control circuitry is to be wired in series with the (Y) circuit to the A.C. unit outside (conventional wiring).
4. Radio receiver must be mounted outside and 4' to 6' above the ground.
5. A red light indicates that a load is being controlled.
6. For control of systems with communicating thermostats, see manufacturers instructions to control outdoor unit and to program thermostat for utility curtailment

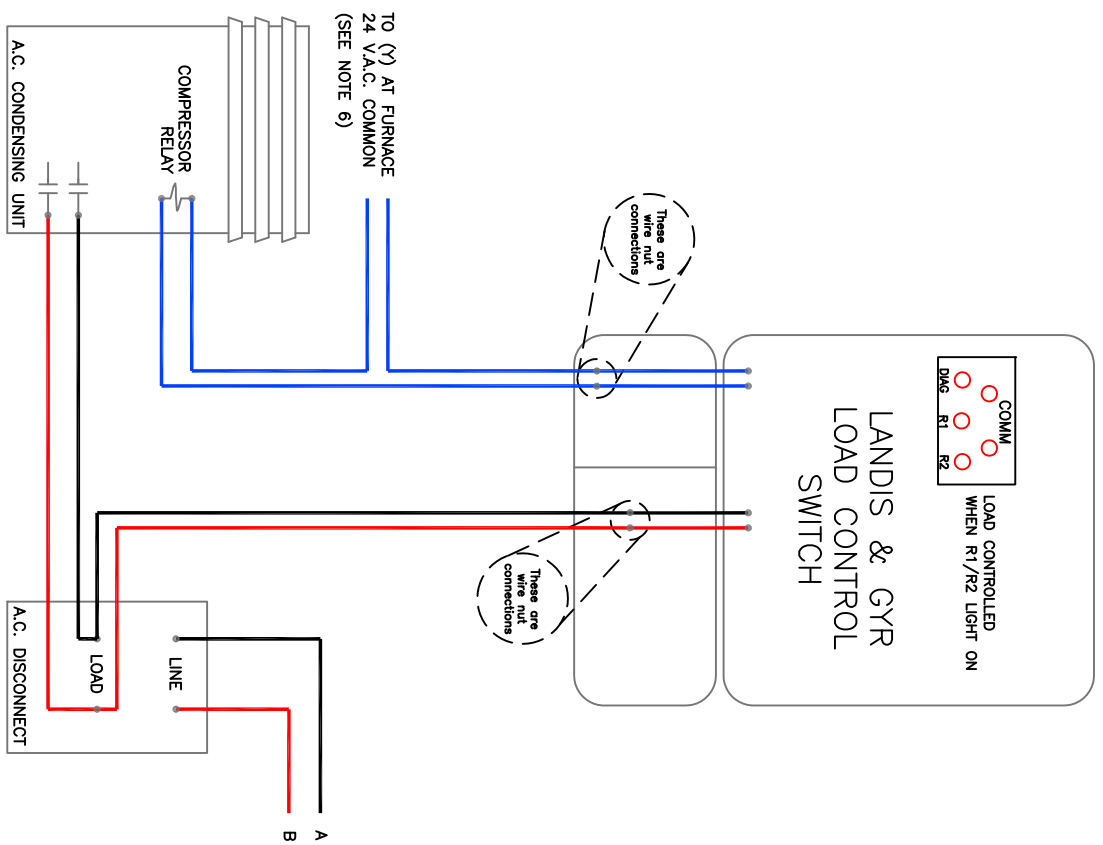

R2 - Orange Wire
 R1 - Blue Wire
 Red
 Black } 240 V.A.C. POWER

R2 WATER STORAGE WHEN THE LIGHT IS ON THE WATER HEATERS ARE TURNED OFF
 R1 ELECTRIC HEAT AND AIR CONDITIONING WHEN THE LIGHT IS ON THE LOAD IS OFF

RETIRESMENT ONLY

 <p>Wright-Hennepin Cooperative Electric Association A Touchstone Energy® Cooperative</p>		<p>WRIGHT-HENNEPIN COOPERATIVE ELECTRIC ASSOCIATION</p>	
<p>ENERGY AND SERVICES DEPARTMENT 1-800-943-2667 QUICK CASH AC/ASHP</p>		<p>DATE 4/19/2024 DWG BY: TLG DWG NO. LM2C</p>	
PROJECT NO.	SCALE N/A	CHKD BY:	APPD BY:
			SHEET 1 OF 1